



SLC TUBO Ø62 WH TED 2700K CRI90 IP54 24°

06/06/2024

3234512



Product description

SLC Design Tubo appears in simple and clear shapes. Its contemporary Scandinavian design lends character to any room and blends into most environments. The design follows the function: Low glare due to the lowered edge of 60 mm. The light source is recessed and not visible from the side angles. It is also suitable for damp rooms, such as bathrooms or spa areas (IP54).

SLC Design Tubo appears in simple and clear shapes. With its contemporary Scandinavian design, it lends character to any room, and at the same time it blends into most environments. Design follows function: Low glare due to the lowered edge of 60 mm. The light source is recessed and not visible from the side angles. Also suitable for use in damp rooms, such as bathrooms or spa areas (IP54).

- Dimmable (TED) driver included
- Recommended dimmer: SLC SmartOne (S240)
- CRI >90 enhances vivid Colours in any environment
- Suitable for outdoor use
- Quick connection box with Loop-in / Loop-Out



Technical data

Suitable for built-in mounting	Yes	Suitable for suspended mounting	No
Suitable for ceiling mounting	Yes	Adjustability	Not adjustable
Lamp type	LED not exchangeable	With light source	Yes
Housing material	Aluminium	Surface protection	Powder coating
Housing colour	White	Material cover	Plastic, transparent
Voltage type	AC	Nominal voltage	220 - 240 Volt
Nominal current	230 - 230 Milliampere	Type of control gear	LED operating device current-controlled
With control gear	Yes	Dimming phase cut-off	Yes
Reflector	High-gloss	Light distributor	Reflector





Light sharing	Symmetric
Beam angle	Medium beam 21-40°
Energy efficiency class of the light source a	G
Degree of protection (IP)	IP54
Rated ambient temperature according to IEC	-10 - 45 Degrees celsius
Max. system power	10 Watt
Colour temperature	2700 - 2700 Kelvin
Luminous flux	506 - 506 Lumen
Power factor	0,95
Luminous flux adjustable	Continuously variable
Width	70 Millimetre
Length	70 Millimetre
Built-in width	62 Millimetre
Built-in length	62 Millimetre
Type of wiring	Suitable for through wiring
Conductor cross section	0,35 Square millimetre
Connection type	Push-in clamp
Luminaire efficacy	56 Lumen/Watt
Covering of the luminaire with thermally ins	No
Power factor	0,95
Operating temperature (Ta)	-10°C ~ +45°C
Control type	Trailing edge
GTIN	7070938054447

Reflector colour	Silver
Light outlet	Direct
Rated life time L70/B50 at 25 °C	50000 Hour
Protection class	II
Suitable for lamp power	9 - 9 Watt
Colour of light	White
Colour rendering index CRI	90-100
Rated luminous flux according to IEC 62722-	560 Lumen
Colour of light adjustable	No
Beam angle adjustable	No
Height/depth	103 Millimetre
Outer diameter	70 Millimetre
Built-in height/depth	43 Millimetre
Built-in diameter	62 - 62 Millimetre
Number of poles	3
Connectable conductor cross section	0,75 - 2,5 Square millimetre
Luminaire with limited surface temperature,	No
Suitable for workplace according to EN 1246	No
Colour consistency (McAdam ellipse)	SDCM3
Beam angle fixed	24
Can be installed directly into the insulation	Yes
Brand	SLC
Produced by	The Light Group



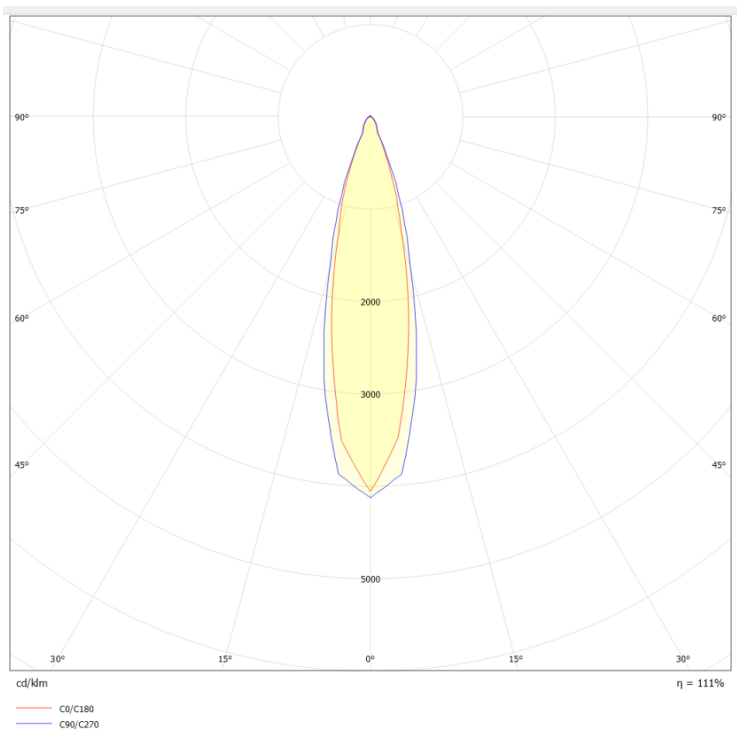
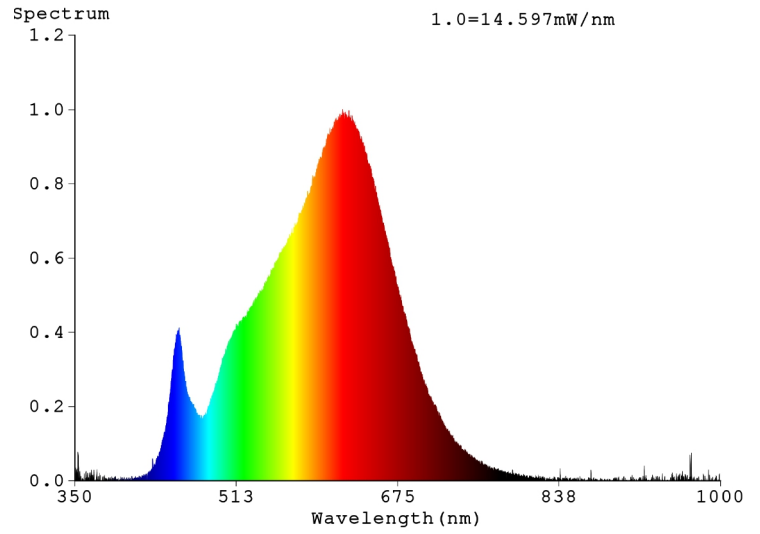
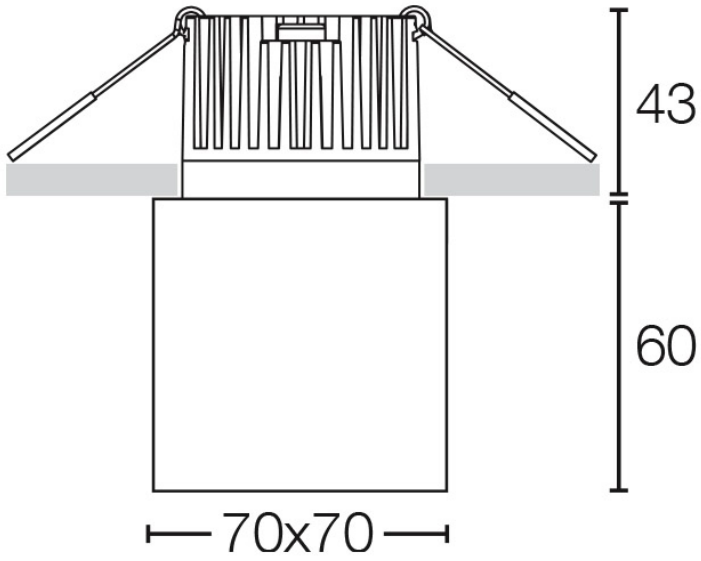

Scandinavian Lighting Concept
3234512

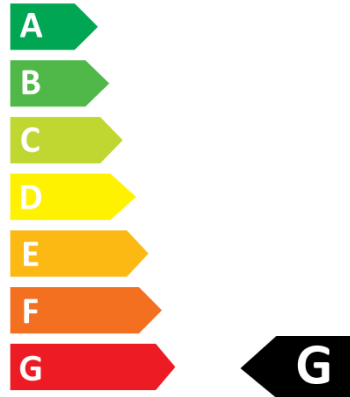

11
kWh/1000h

